

# DC METAL FRAME FAN TRS2510 E SERIES 25X25X10mm

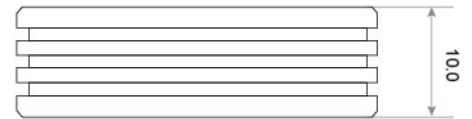
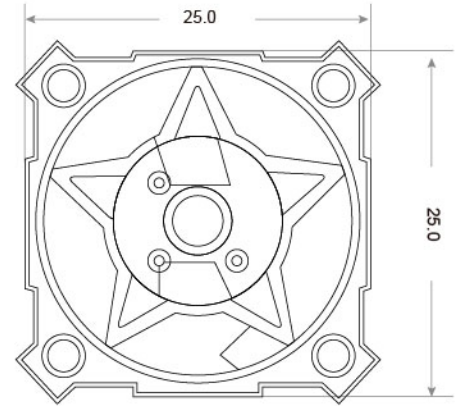

- Frame : Thermoplastic Aluminum alloy  
外框材質：環保防火 鋁合金
- Impeller : Thermoplastic PBT UL94-V0  
扇葉材質：環保防火PBT
- Bearing System : Sleeve Bearing/WRB Bearing/Two Ball Bearing  
軸承結構：※含油軸承/★專利軸承/◎滾珠軸承
- Unit Weight : 15g  
風扇單體重量：15克

Model No.	Bearing Type	Voltage (VDC)	Current (A)	Power (W)	Speed (RPM)	Air Flow (CFM)	Air Flow (m <sup>3</sup> /min)	Air Pressure (mmHzO)	Air Pressure (Inch H <sub>2</sub> O)	Noise (dBA)
TRS2510x05D	※★◎	5 (3.5~7.0)	0.06	0.30	5000	0.86	0.024	1.58	0.060	14.0
TRS2510x05L	※★◎	5 (3.5~7.0)	0.09	0.45	7000	1.21	0.034	2.18	0.085	19.6
TRS2510x05M	※★◎	5 (3.5~7.0)	0.13	0.65	10000	1.99	0.056	4.48	0.176	22.8
TRS2510x05H	※★◎	5 (3.5~7.0)	0.17	0.85	12000	2.38	0.067	7.37	0.290	25.2
TRS2510x05VH	※★◎	5 (3.5~7.0)	0.25	1.25	25000	5.00	0.140	13.30	0.520	46.0
TRS2510x12L	※★◎	12 (6.0~14.0)	0.03	0.36	7000	1.21	0.034	2.18	0.085	19.6
TRS2510x12M	※★◎	12 (6.0~14.0)	0.05	0.60	10000	1.99	0.056	4.48	0.176	22.8
TRS2510x12H	※★◎	12 (6.0~14.0)	0.08	0.96	12000	2.38	0.067	7.37	0.290	25.2
TRS2510x12VH	※★◎	12 (6.0~14.0)	0.10	1.20	15000	2.98	0.084	7.98	0.314	28.9
TRS2510x24L	※★◎	24 (18.0~27.0)	0.03	0.72	7000	1.21	0.034	2.18	0.085	19.6
TRS2510x24H	※★◎	24 (18.0~27.0)	0.05	1.20	12000	2.38	0.067	7.37	0.290	25.2

★產品詳細數據及功能請參閱承認書 Product have a detail in the approval sheet.  
★產品規格變更不另行通知 Specifications are subject to change without notice.

⊗ Bearing System ※ : Sleeve ★ : WRB Bearing ◎ : Ball