

# DC METAL FRAME FAN TRS3010 E SERIES 30X30X10mm

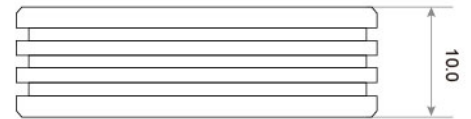
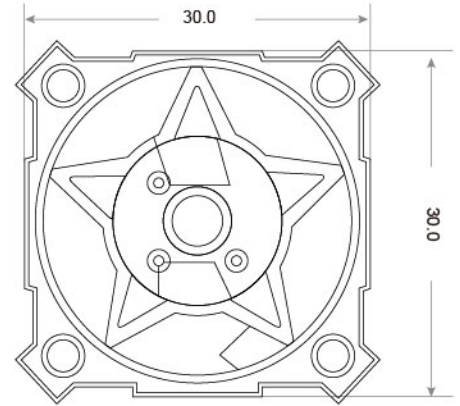

- Frame : Thermoplastic Aluminum alloy  
外框材質：環保防火 鋁合金
- Impeller : Thermoplastic PBT UL94-V0  
扇葉材質：環保防火PBT
- Bearing System : Sleeve Bearing/WRB Bearing/Two Ball Bearing  
軸承結構：※含油軸承/★專利軸承/◎滾珠軸承
- Unit Weight : 9g  
風扇單體重量：9克

Model No.	Bearing Type	Voltage (VDC)	Current (A)	Power (W)	Speed (RPM)	Air Flow (CFM)	Air Flow (m <sup>3</sup> /min)	Air Pressure (mmH <sub>2</sub> O)	Air Pressure (Inch H <sub>2</sub> O)	Noise (dBA)
TRS3010x05D	※◎★	5 (3.5~6.8)	0.10	0.50	5500	0.90	0.025	2.270	0.089	23.4
TRS3010x05L	※◎★	5 (3.5~6.8)	0.12	0.60	6000	1.07	0.030	2.860	0.113	25.0
TRS3010x05M	※◎★	5 (3.5~6.8)	0.13	0.65	6500	1.16	0.033	3.350	0.132	26.5
TRS3010x05H	※◎★	5 (3.5~6.8)	0.14	0.70	7000	1.23	0.035	3.910	0.154	28.7
TRS3010x05VH	※◎★	5 (3.5~6.8)	0.16	0.80	7500	1.31	0.037	4.491	0.177	30.0
TRS3010x05SH	※◎★	5 (3.5~6.8)	0.18	0.90	8000	0.36	0.038	5.310	0.209	31.7
TRS3010x05UH	※◎★	5 (3.5~6.8)	0.20	1.00	8500	1.39	0.039	5.860	0.231	33.2
TRS3010x12D	※◎★	12 (6.0~13.5)	0.04	0.50	5500	0.90	0.025	2.270	0.089	23.4
TRS3010x12L	※◎★	12 (6.0~13.5)	0.05	0.60	6000	1.07	0.030	2.860	0.113	25.0
TRS3010x12M	※◎★	12 (6.0~13.5)	0.05	0.65	6500	1.16	0.033	3.350	0.132	26.5
TRS3010x12H	※◎★	12 (6.0~13.5)	0.06	0.70	7000	1.23	0.035	3.910	0.154	28.7
TRS3010x12VH	※◎★	12 (6.0~13.5)	0.07	0.80	7500	1.31	0.037	4.490	0.177	30.0
TRS3010x12SH	※◎★	12 (6.0~13.5)	0.08	0.90	8000	1.36	0.038	5.310	0.209	31.7
TRS3010x12UH	※◎★	12 (6.0~13.5)	0.08	1.00	8500	1.39	0.039	5.860	0.231	33.2
TRS3010x24L	※◎★	24 (18.0~26.5)	0.03	0.72	6000	1.07	0.030	2.860	0.113	25.0
TRS3010x24H	※◎★	24 (18.0~26.5)	0.04	0.96	7000	1.23	0.035	3.910	0.154	28.7
TRS3010x24SH	※◎★	24 (18.0~26.5)	0.05	1.20	8000	1.36	0.038	5.310	0.209	31.7

★產品詳細數據及功能請參閱承認書 Product have a detail in the approval sheet.  
★產品規格變更不另行通知 Specifications are subject to change without notice.