

# DC METAL FRAME FAN TRS3510 E SERIES 35X35X10mm

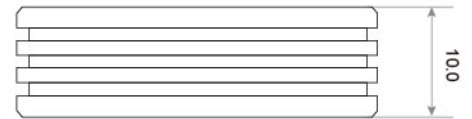
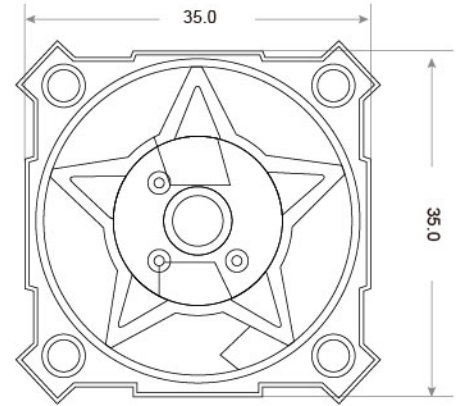

- Frame : Thermoplastic Aluminum alloy  
外框材質：環保防火 鋁合金
- Impeller : Thermoplastic PBT UL94-V0  
扇葉材質：環保防火PBT
- Bearing System : Sleeve Bearing/WRB Bearing/Two Ball Bearing  
軸承結構：※含油軸承/★專利軸承/◎滾珠軸承
- Unit Weight : 9g  
風扇單體重量：9克

Model No.	Bearing Type	Voltage (VDC)	Current (A)	Power (W)	Speed (RPM)	Air Flow (CFM)	(m <sup>3</sup> /min)	Air Pressure (mmH <sub>2</sub> O)	(Inch H <sub>2</sub> O)	Noise (dBA)
TRS3510x05L	※★◎	5 (3.5~7.0)	0.09	0.45	5000	3.85	0.10	1.31	0.05	21.3
TRS3510x05M	※★◎	5 (3.5~7.0)	0.13	0.65	6800	5.67	0.16	2.65	0.10	27.2
TRS3510x05H	※★◎	5 (3.5~7.0)	0.15	0.75	8000	7.02	0.19	3.50	0.14	31.5
TRS3510x05VH	※★◎	5 (3.5~7.0)	0.21	1.05	10000	8.67	0.25	4.23	0.17	34.2
TRS3510x05SH	※★◎	5 (3.5~7.0)	0.24	1.20	11500	9.61	0.27	4.84	0.19	35.3
TRS3510x12L	※★◎	12 (6.0~18.0)	0.04	0.48	5000	3.85	0.10	1.31	0.05	21.3
TRS3510x12M	※★◎	12 (6.0~18.0)	0.06	0.72	8000	5.67	0.16	2.65	0.10	27.2
TRS3510x12H	※★◎	12 (6.0~18.0)	0.08	0.96	10000	7.02	0.19	3.50	0.14	31.5
TRS3510x12VH	※★◎	12 (6.0~18.0)	0.09	1.08	11500	8.67	0.25	4.23	0.17	34.2
TRS3510x12SH	※★◎	12 (6.0~18.0)	0.10	1.20	6800	9.61	0.27	4.84	0.19	35.3
TRS3510x24H	※★◎	24 (18.0~27.0)	0.05	1.20	8000	7.02	0.19	3.50	0.14	31.5
TRS3510x24VH	※★◎	24 (18.0~27.0)	0.10	2.40	10000	8.67	0.25	4.23	0.17	34.2

★產品詳細數據及功能請參閱承認書 Product have a detail in the approval sheet.  
★產品規格變更不另行通知 Specifications are subject to change without notice.

⊗ Bearing System ※ : Sleeve ★ : WRB Bearing ◎ : Ball