

# DC Forward Centrifugal Fan SDF3P133-DC072 SERIES 175X181X88mm

- Material : Galvanized sheet steel  
材質：鍍鋅板材
- Bearing System : Two Ball Bearing  
軸承結構：滾珠軸承
- Unit Weight : 3100g  
風扇單體重量：3100克

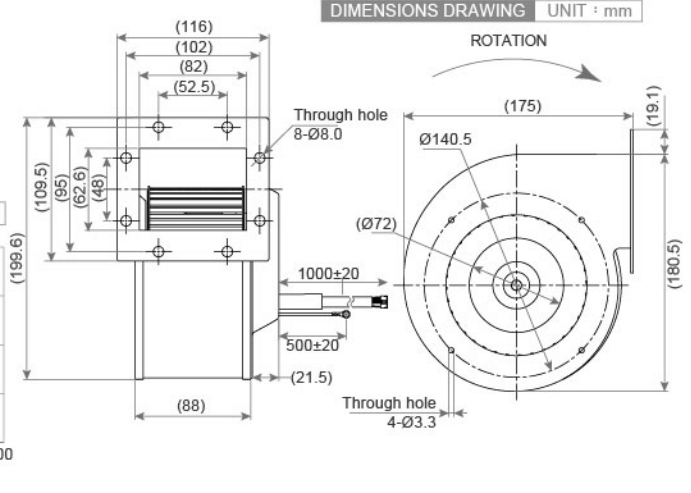
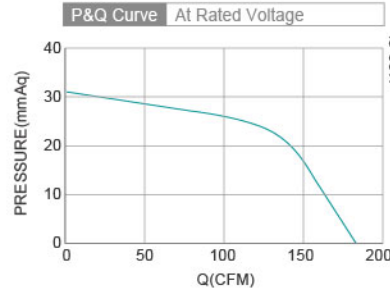

Model No.	Bearing Type	Voltage (VDC)	Current (A)	Power (W)	Speed (RPM)	Air Flow (CFM)	Air Flow (m <sup>3</sup> /min)	Air Pressure (mmH <sub>2</sub> O)	Air Pressure (Inch H <sub>2</sub> O)	Noise (dBA)
SDF3P133-DC072-A31	◎	310	0.21	65.0	2100	182.0	5.15	32.01	1.26	59.0

⊗ Bearing System ※ : Sleeve ★ : WRB ◎ : Ball

★如果您需要的轉速或電壓或功能不在這份清單上，請與我們業務聯繫 Please contact us, if the SPEC you need is not in the list.

★產品詳細數據及功能請參閱承認書 Please see the approval sheet for more information . ★產品規格變更不另行通知 Specifications are subject to change without notice. C1